

MAPLE OVENS

1011 PE COMBI OVEN



MAPLE

RIMASEE CORP.

1500 Grand Concourse Suite 41B,
Bronx, NY 10457
(347) 809 3544 / (646) 919 2500

www.maple-ovens.com
info@maple-ovens.com



1011 PE Combi Oven



CODE: 925907630

Technical features

Outside Dimensions:	28 1/8" L 31 1/2" W 39 3/8" H
Space Between Trays:	2 9/16"
Trays:	10 Trays GN 1/1
Power:	11 KW - 45 Amps
Weight:	176 lbs
Max Temperature:	518 °F
Power Supply:	230 V ~ 3PH + PE 230 V ~ 1PH + N + PE 50-60 Hz

Equipment

Capacitive Touch screen 7"	6 Cooking modes	5 Fan speeds
LED lighting	Core probe	HACCP register
Pre-heating option	Controlled steam injection (%)	Online collection of recipes
Cooling system	Fan inversion system	Multi-timer tray cooking end
10 Phases for cooking	Multipoint probe	Glass opening for cleaning
Delayed cooking programming	Error reporting	USB port

Accessories

Cabinets, Blast chillers, Exhaust & draining, Cleaning & purification, Control tools, Stands & supports, Trays

1011 PE Combi Oven

CODE: 925907630

Spec Drawing - Electrical Supply

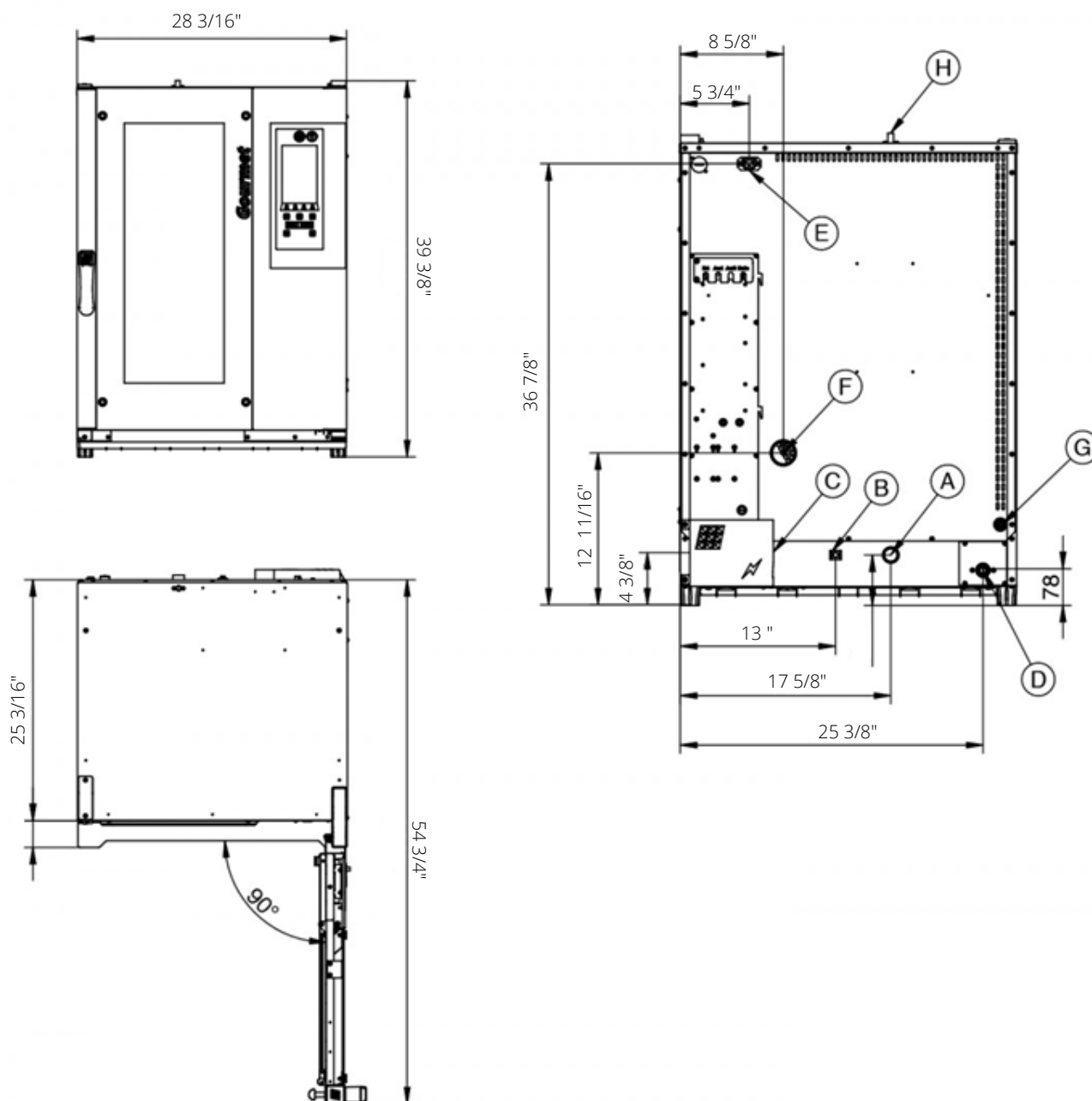

Legend

- A - Drain liquid Ø 30mm
- B - Equipotential terminal comb
- C - Electric supply
- D - Water inlet 3/4"
- E - Extracting hood supply
- F - Steam exhaust Ø 50mm
- G - Inlet for washing kit Ø 8mm
- H - Depressurizer Ø 12mm



1011 PE Combi Oven

CODE: 925907630

Connections

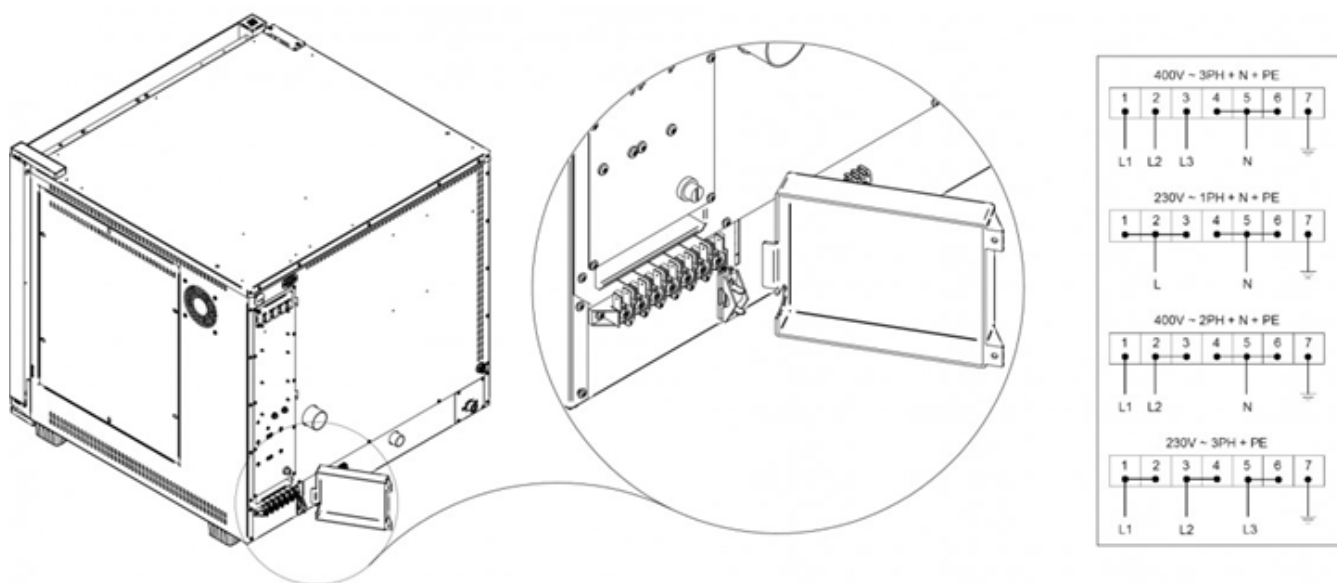

Packaging

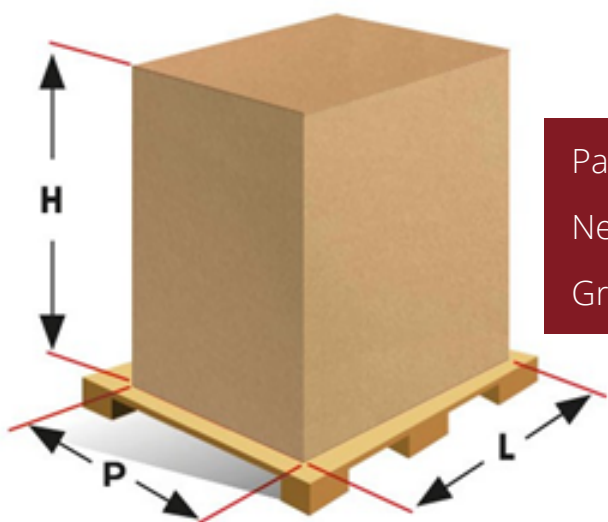

Packaging Size: 31 1/8" L 34 1/4" P 44 7/8" H

Net Weight: 192 lbs

Gross Weight: 212lbs

1500 Grand Concourse Suite 41B,
Bronx, NY 10457
(347) 809 3544 / (646) 919 2500



www.maple-ovens.com
info@maple-ovens.com