

MAPLE OVENS

1065 PE COMBI OVEN



MAPLE

RIMASEE CORP.

1500 Grand Concourse Suite 41B,
Bronx, NY 10457
(347) 809 3544 / (646) 919 2500

www.maple-ovens.com
info@maple-ovens.com



1065 PE Combi Oven



CODE: 925913130

Technical features

Outside Dimensions:	33 7/16" L 36 5/8" W 45 1/4" H
Space Between Trays:	3 3/16"
Trays:	10 Trays 18" x 26"
Power:	15 KW - 68 Amps
Weight:	243 lbs
Max Temperature:	518 °F
Power Supply:	230 V ~ 3PH + PE 230 V ~ 1PH + N + PE 50-60 Hz

Equipment

Capacitive Touch screen 7"	6 Cooking modes	5 Fan speeds
LED lighting	Core probe	HACCP register
Pre-heating option	Controlled steam injection (%)	Online collection of recipes
Cooling system	Fan inversion system	Multi-timer tray cooking end
10 Phases for cooking	Multipoint probe	Glass opening for cleaning
Delayed cooking programming	Error reporting	USB port

Accessories

Cabinets, Blast chillers, Exhaust & draining, Cleaning & purification, Control tools, Stands & supports, Trays

1065 PE Combi Oven

CODE: 925913130

Spec Drawing - Electrical Supply

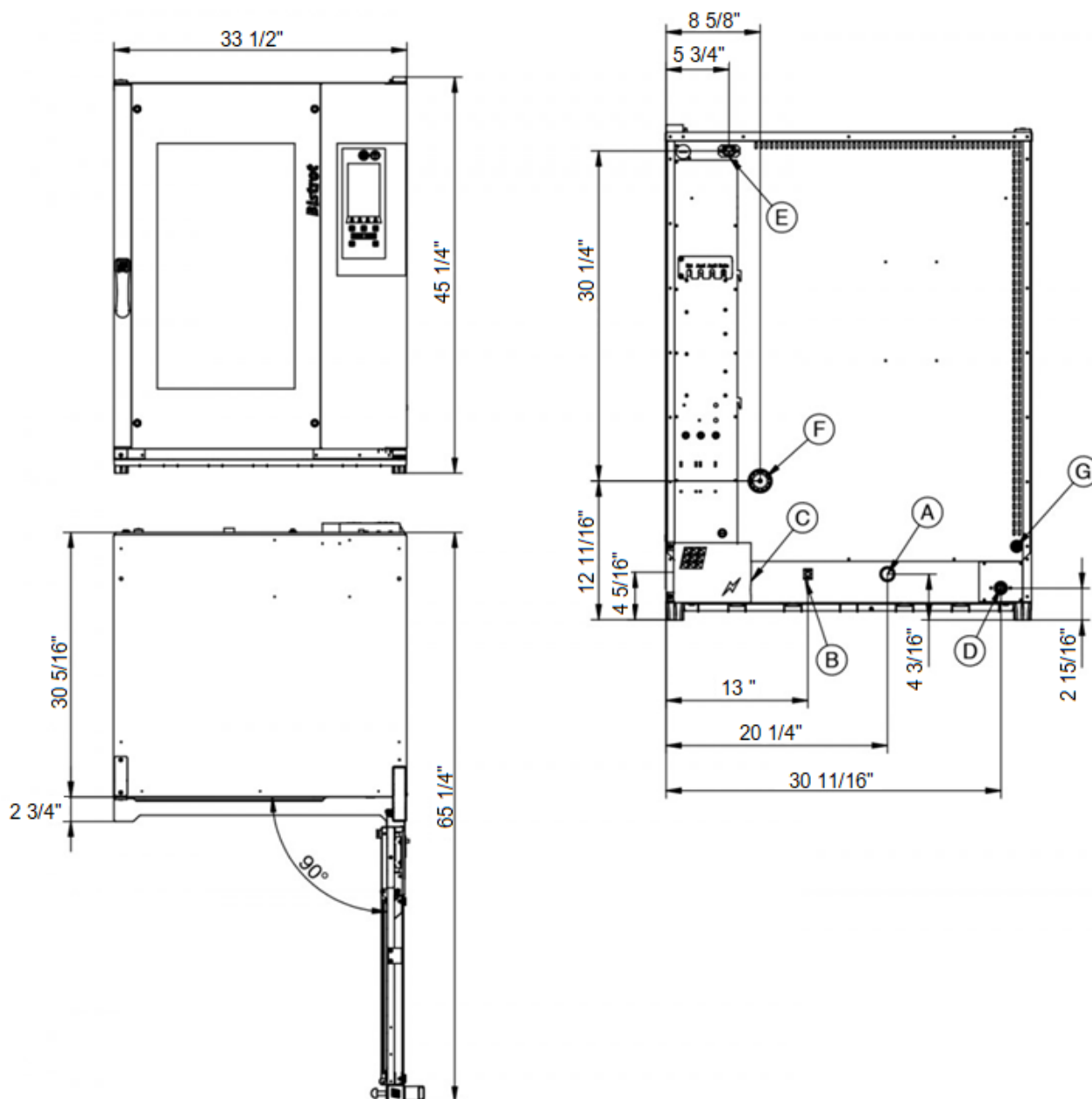

Legend

- A - Drain liquid \varnothing 30mm
- B - Equipotential terminal comb
- C - Electric supply
- D - Water inlet $\frac{3}{4}$ "
- E - Extracting hood supply
- F - Steam exhaust \varnothing 50mm
- G - Inlet for washing kit \varnothing 8mm
- H - Depressurizer \varnothing 12mm



1065 PE Combi Oven

CODE: 925913130

Connections

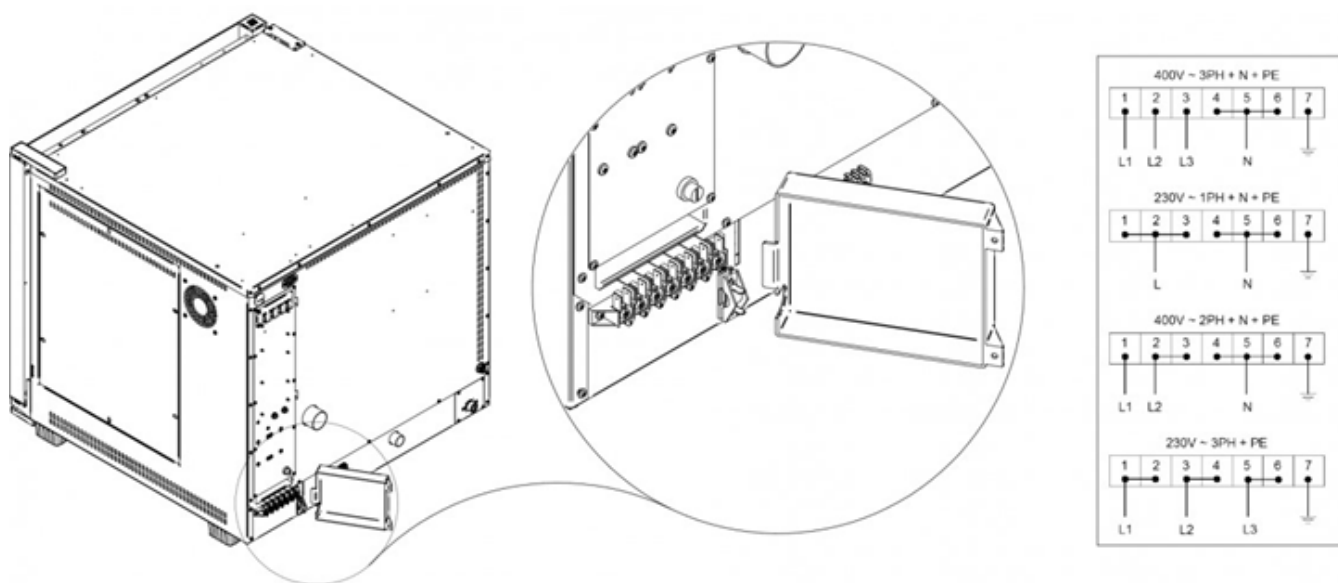

Packaging

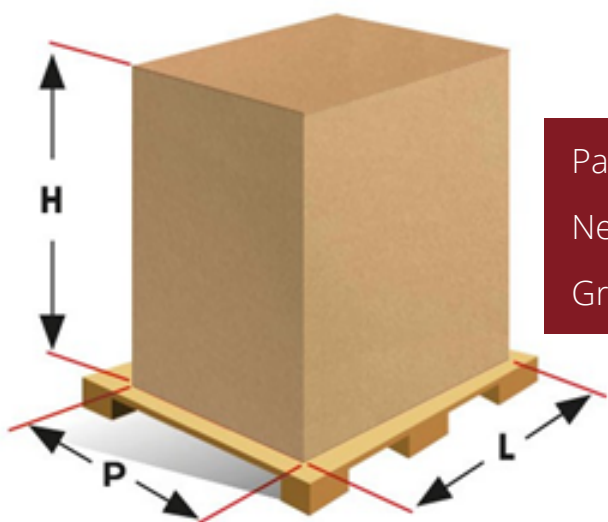

Packaging Size: 36 1/4" L 39 3/8" P 51 3/16" H

Net Weight: 267 lbs

Gross Weight: 289 lbs

1500 Grand Concourse Suite 41B,
Bronx, NY 10457
(347) 809 3544 / (646) 919 2500



www.maple-ovens.com
info@maple-ovens.com