

MAPLE OVENS

**523 CE
COMBI OVEN**



MAPLE

RIMASEE CORP.

1 Ace Street Unit 231,
Fall River, MA 02720
(347) 809 3544 / (646) 919 2500

www.maple-ovens.com
info@maple-ovens.com



523 CE Combi Oven



CODE: 925904620

Technical features

Outside Dimensions:	24 7/16" L 29 1/2" W 24 3/16" H
Space Between Trays:	2 3/8"
Trays:	5 Trays GN 2/3
Power:	3.2 KW - 14 Amps (Mono)
Weight:	100 lbs
Max Temperature:	518 °F
Power Supply:	230 V ~ 3PH + PE 230 V ~ 1PH + N + PE 50-60 Hz

Equipment

Touch screen	6 Cooking modes	5 Fan speeds
LED lighting	Core probe	HACCP register
Pre-heating option	Controlled steam injection (%)	Online collection of recipes
Cooling system	Fan inversion system	Multi-timer tray cooking end
10 Phases for cooking	Multipoint probe	Glass opening for cleaning
Delayed cooking programming	Error reporting	USB port

Accessories

Cabinets, Blast chillers, Exhaust & draining, Cleaning & purification, Control tools, Stands & supports, Trays

523 CE Combi Oven

CODE: 925904620

Connections

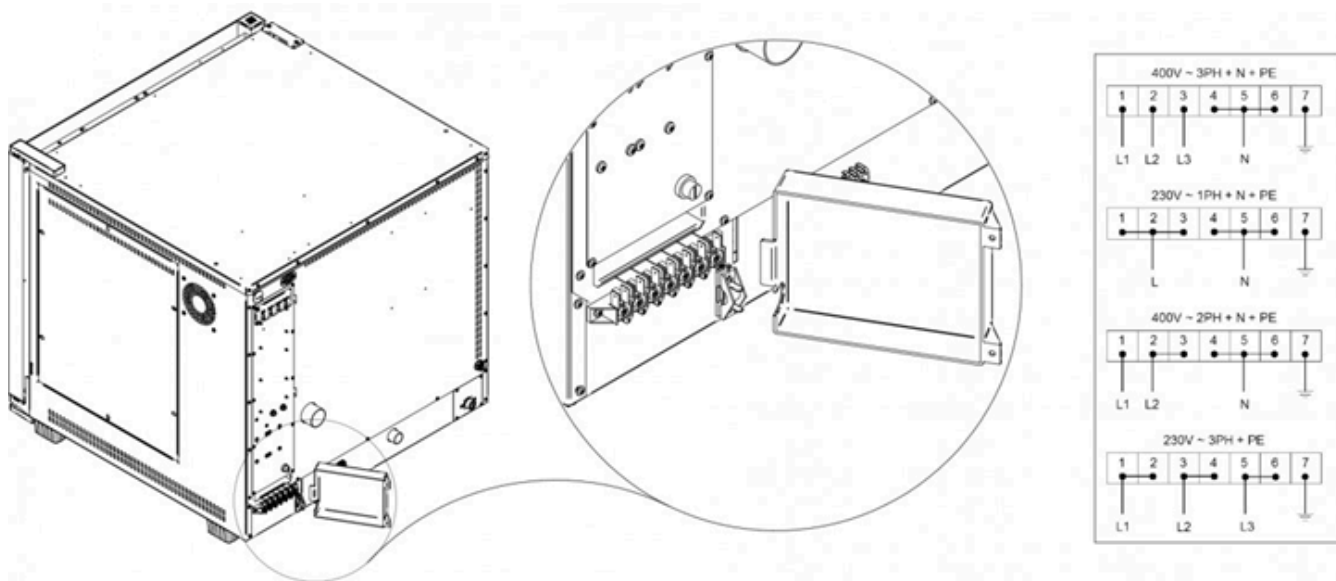

Packaging

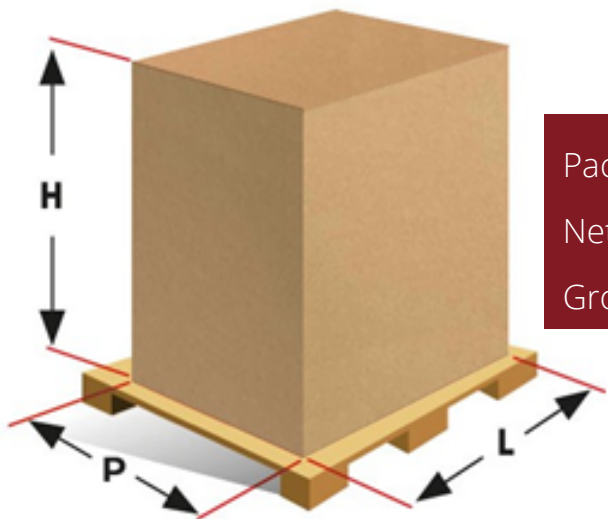

Packaging Size: 27 9/16"L 32 11/16"D 330 5/16"H

Net Weight: 100 lbs

Gross Weight: 117 lbs

1 Ace Street Unit 231,
 Fall River, MA 02720
 (347) 809 3544 / (646) 919 2500



www.maple-ovens.com
 info@maple-ovens.com